



K-200 SERIES

HOT WATER SANITIZING SINGLE-TANK RACK CONVEYOR DISHWASHERS

The clean solution

Special Features:

- **Low water consumption** - 84.7 gallons (320.6 liters) per hour, 0.35 gallons (1.34 liters) per rack
- **Pumped final rinse** isolates the machine from variations in water supply pressure, ensuring consistent results
- **Pumped auxiliary rinse zone** supplements the final rinse for improved rinsing and increased efficiency
- **Standard Waste Air Heat Recovery System** reclaims the waste heat generated by the machine and uses it as free energy to preheat the incoming rinse water. This reduces energy consumption and allows hot water sanitization from a cold water supply (as low as 50°F / 10°C)
- **Standard internal booster heater** works with the Waste Air Heat Recovery System for improved efficiency
- **MIKE 3 electronic controller** for fully automatic operation and advanced service diagnostics. Each zone activates water flow only when a rack enters the zone to conserve water, energy and detergent

Standard Features:

- Capacity **240** racks per hour
- Water consumption **0.35** gallons (1.34 liters) per rack
- 304-series stainless steel construction
- Double-wall insulated construction on front, top and back to improve operator safety, conserve heating energy, and reduce noise and heat loss into the dishroom
- Improved side-drive system ensures complete water coverage from every angle, even the bottom of the rack, while reducing jerking motions that can shift ware
- Large, easily-removed pan strainer(s). Models equipped with a prewash include a separate prewash scrap basket
- Large, insulated front door(s) are spring-loaded to open easily and STAY open, without latching
- Optimally-positioned wash arms in easily-removed assemblies. Arms and assemblies are stainless steel, eliminating high-wear gaskets and O-rings. Nozzles are slotted and concave to minimize clogging
- Front-sloping tanks for easier cleaning. External, foot-lever drain system makes draining fast, safe and simple
- Powerful 3hp (2.2 kW) wash pump is 50% more powerful than the industry standard for outstanding cleaning ability. Pump motor is vertically-mounted to be self-draining and easily removed for servicing
- Easily accessible detergent and rinse aid injection ports for fast and easy chemical dispenser installation
- Single-point drain connection
- Single-point powered vent connection
- Low-level heater protection
- External vent fan control



Options:

- Revolutionary blower drying system - uses only 3 kW of heating energy. Available in two lengths for a variety of ware requirements
- CSS Top Chemical Savings System - acts as a pre-rinse to reduce the need for pre-scraping; processes water continuously through cyclone separators to remove food soil; reduces detergent consumption by up to 50%
- Hinged front access door(s)
- Steam coil or electric heating
- Single-point electrical connection
- Table limit switch (end stop or whisker switch versions)
- Direct drive sideloader
- 90° powered loader or unloader
- Flanged feet
- Drain water tempering kit

Models:

- K-200: 6' 4-3/4" (1950mm) chamber with wash, auxiliary rinse and final rinse zones
- K-200 PW: Adds 19-5/8" (500mm) prewash to K-200 configuration. Overall length 8' 1/2" (2450mm)
- K-200 LPW: Adds 31-1/2" (800mm) prewash to K-200 configuration. Overall length 9' 1/4" (2750mm)

This dishwasher is compliant with the Reduction of Lead in Drinking Water Act (2011) amendment to the Safe Drinking Water Act (SDWA).



K-200 Series, left-to-right - electric heat

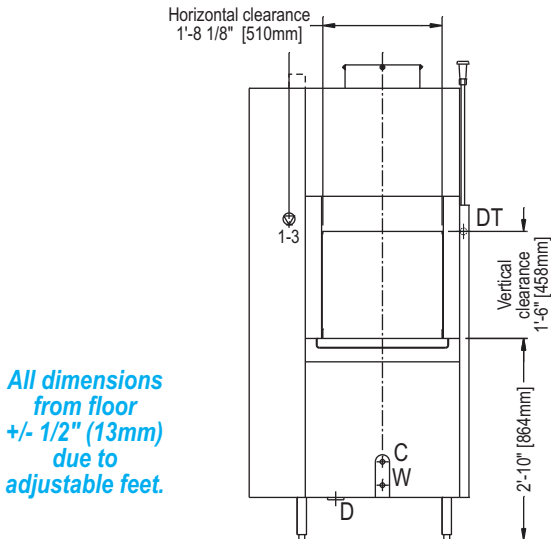
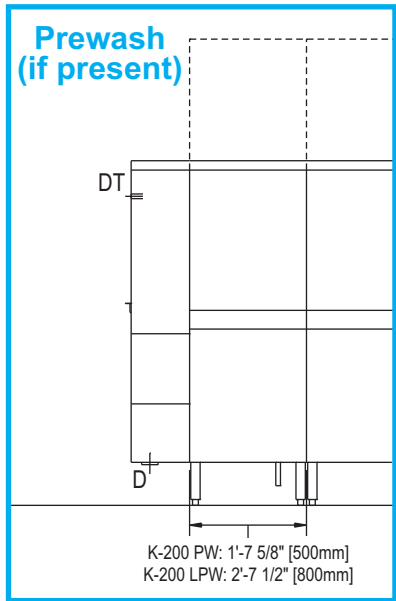
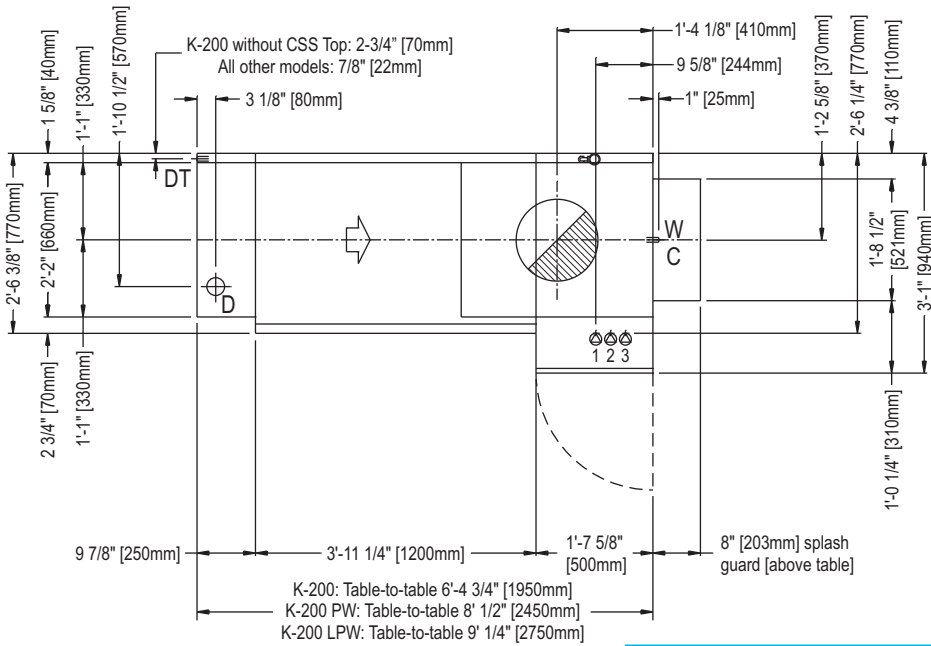
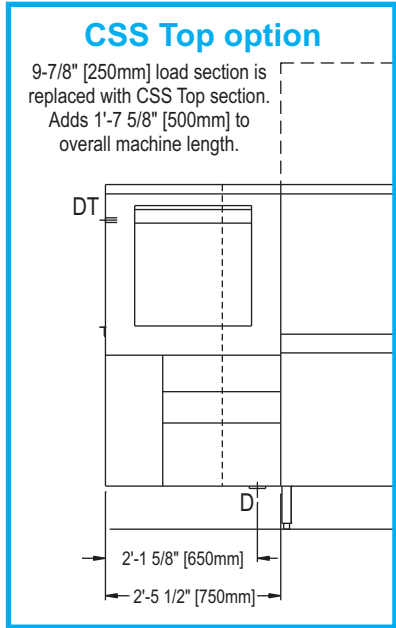
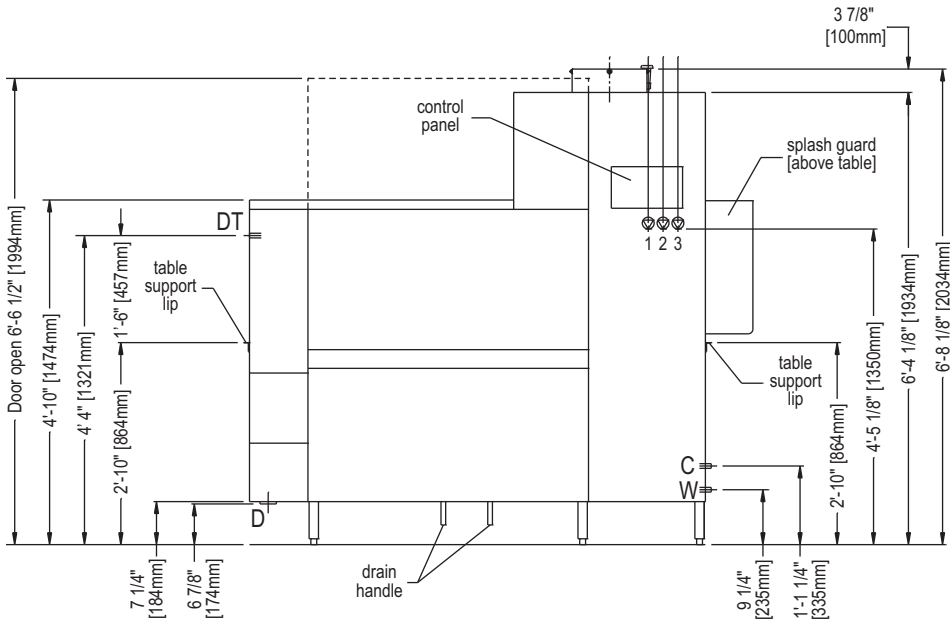

All dimensions from floor +/- 1/2" (13mm) due to adjustable feet.

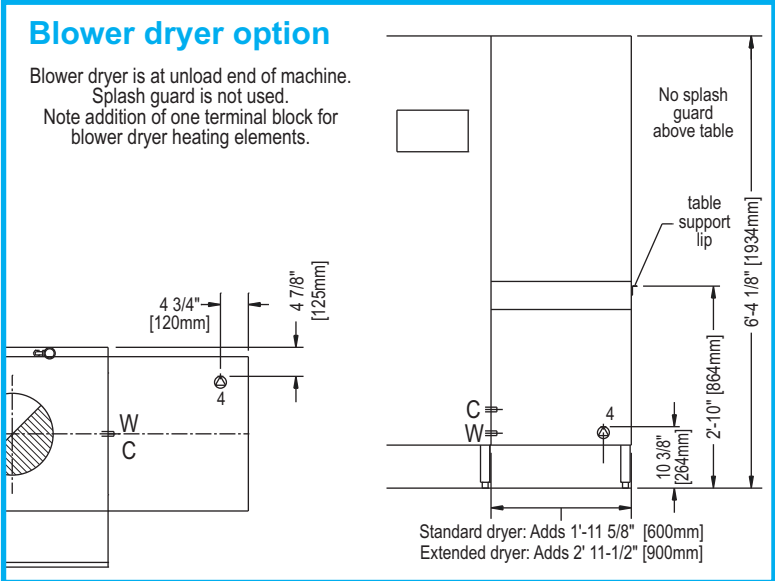

K-200 Series, right-to-left - electric heat

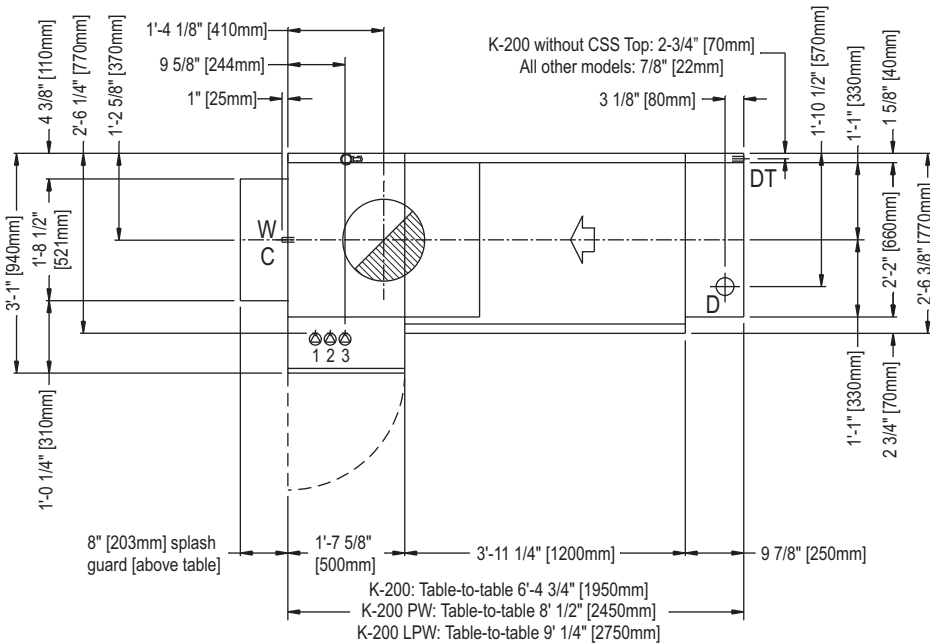
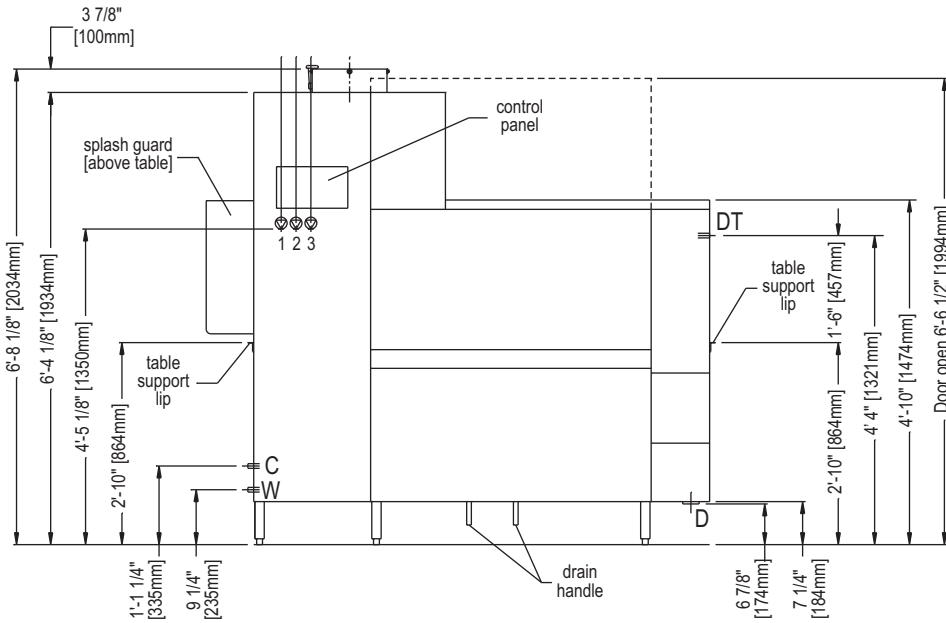

CSS Top option

9-7/8" [250mm] load section is replaced with CSS Top section. Adds 1'-7 5/8" [500mm] to overall machine length.

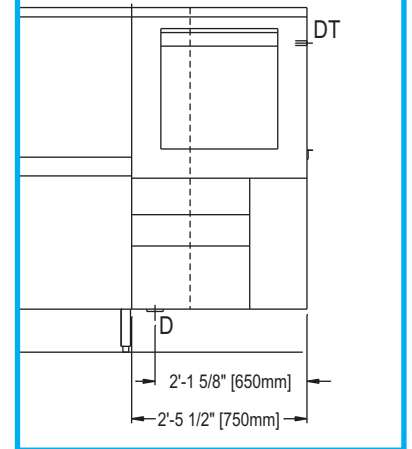

Prewash (if present)

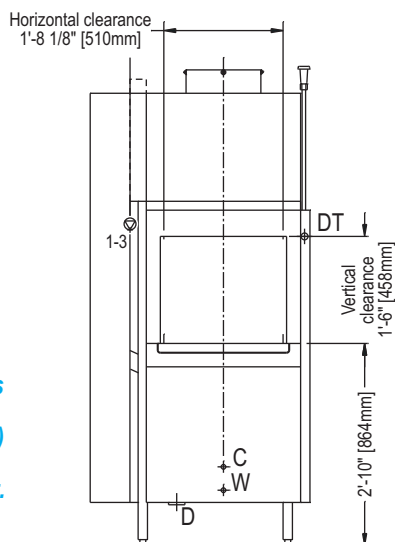
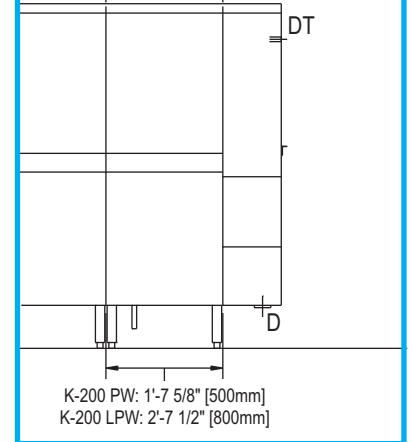

All dimensions from floor +/- 1/2" (13mm) due to adjustable feet.

Blower dryer option

Blower dryer is at unload end of machine. Splash guard is not used. Note addition of one terminal block for blower dryer heating elements.

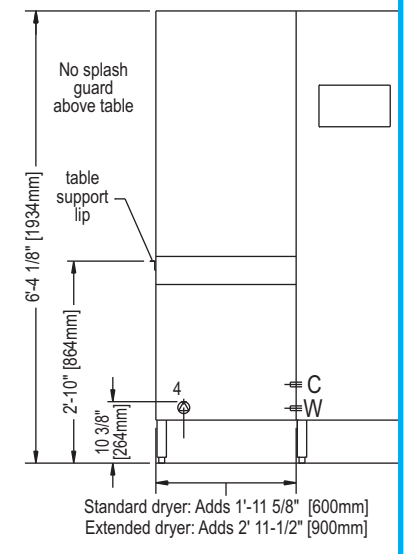
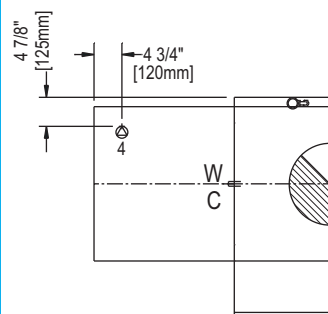

K-200 Series, left-to-right - steam heat

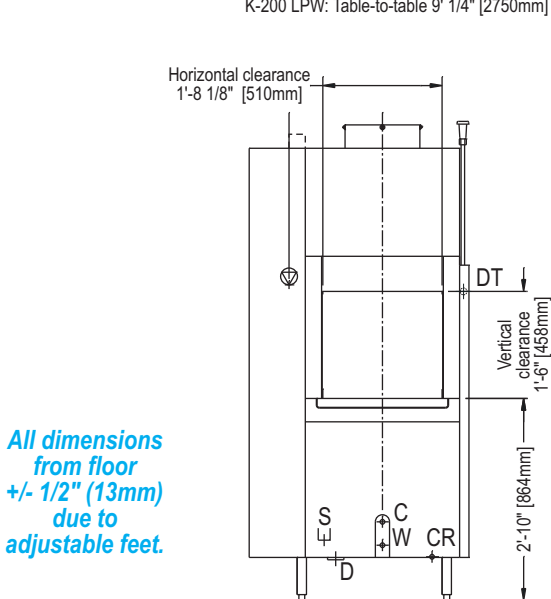
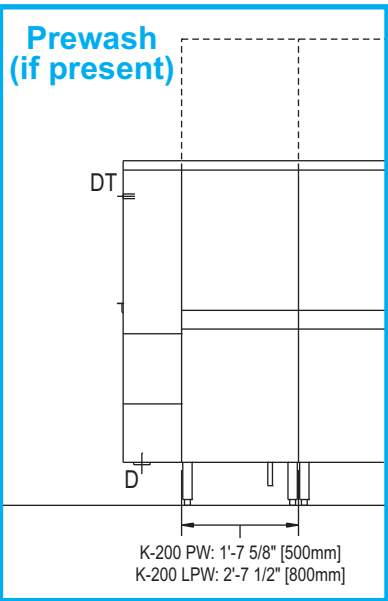
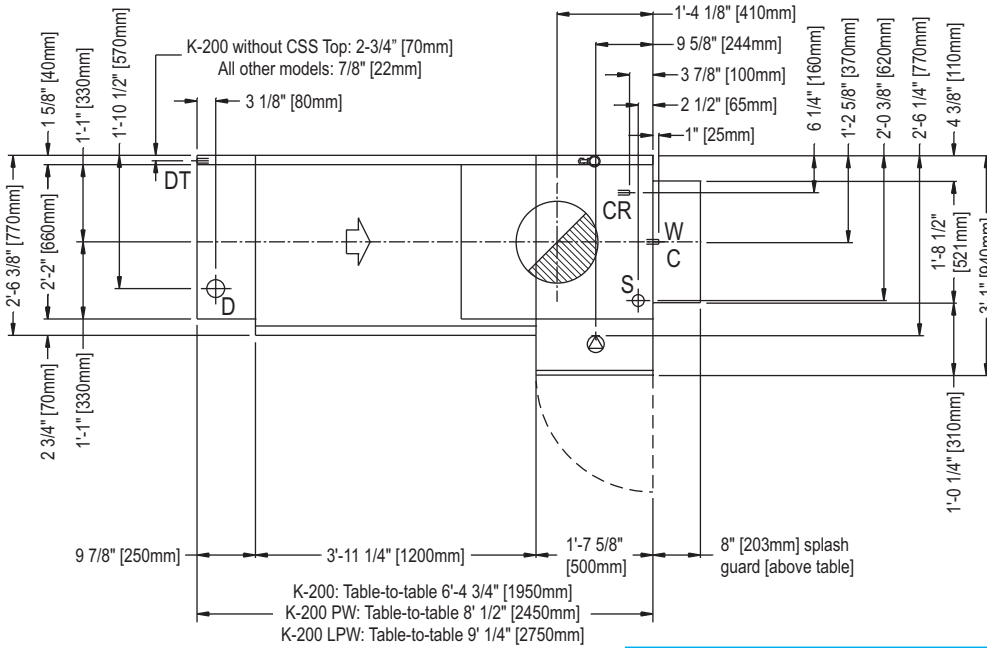
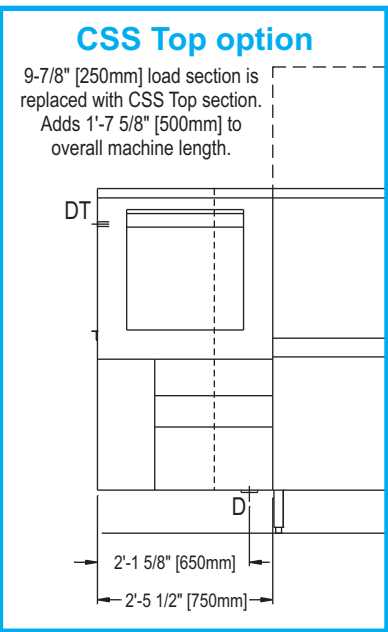
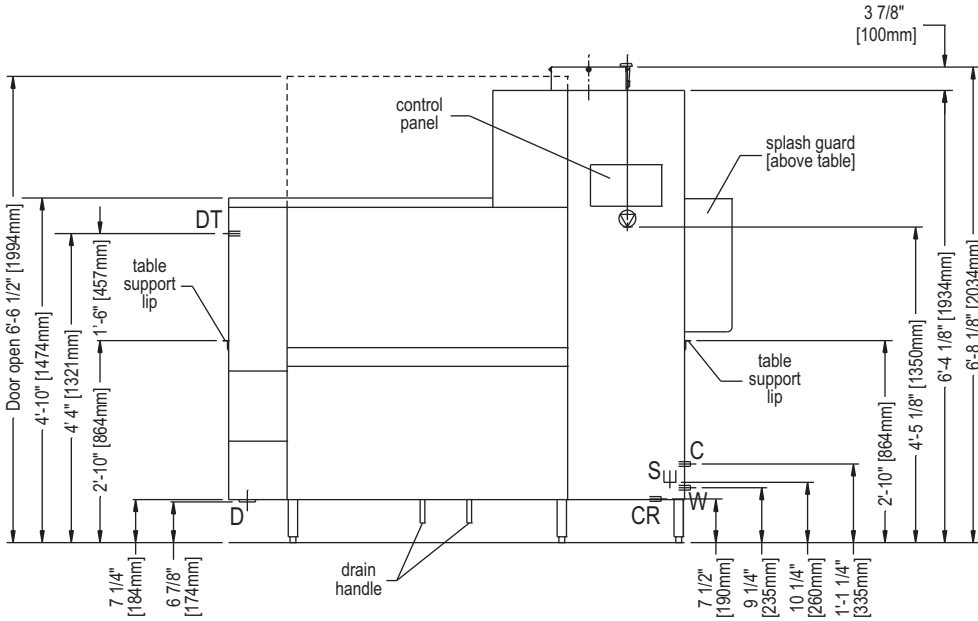

All dimensions from floor +/- 1/2" (13mm) due to adjustable feet.

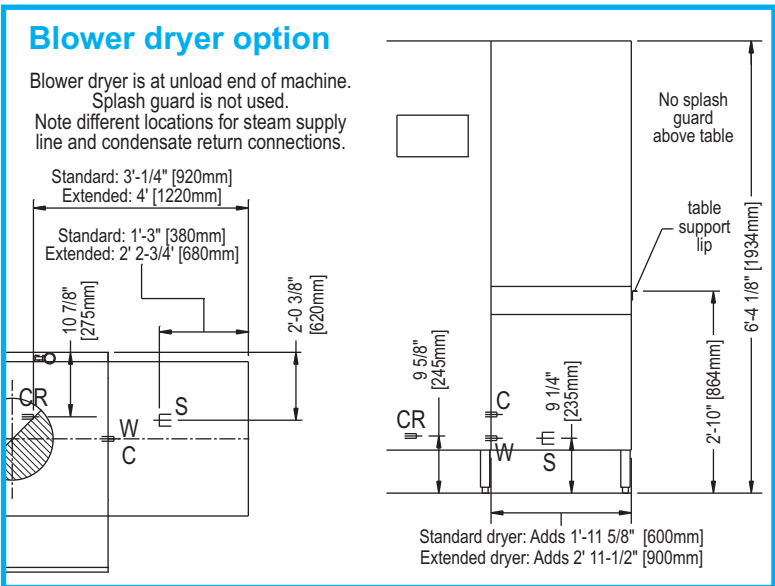

K-200 Series, right-to-left - steam heat

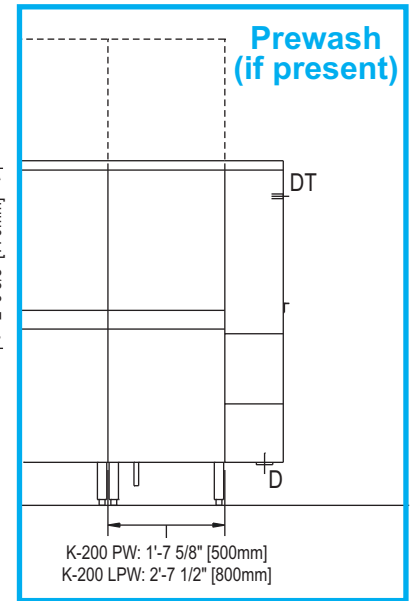
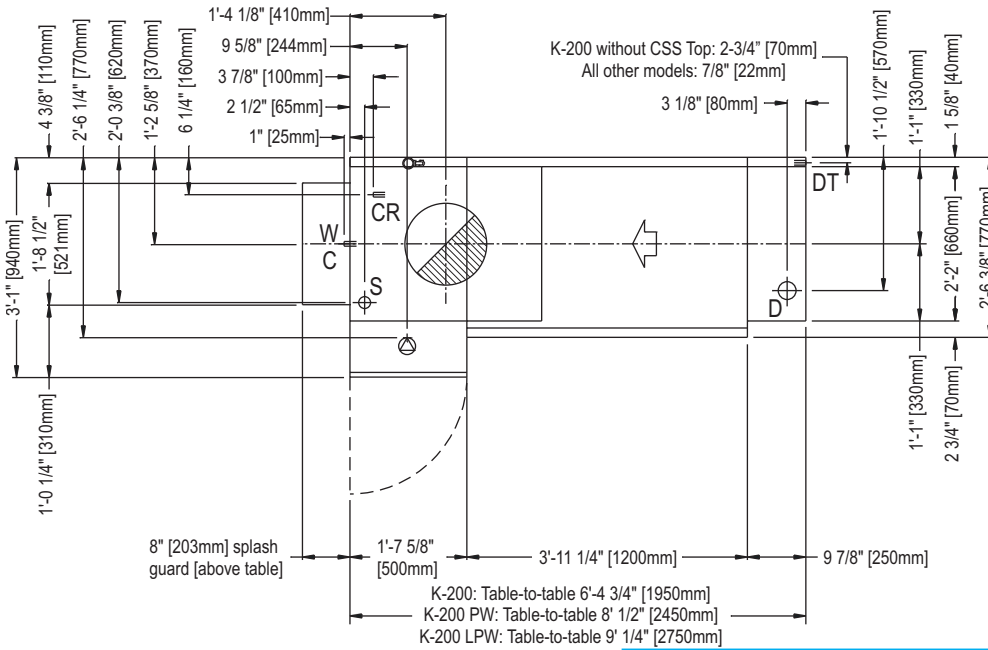
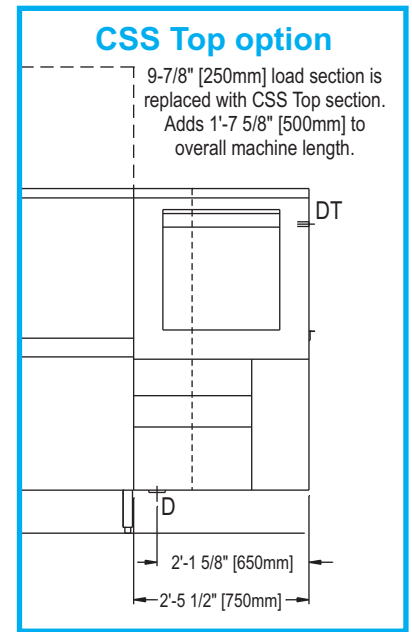
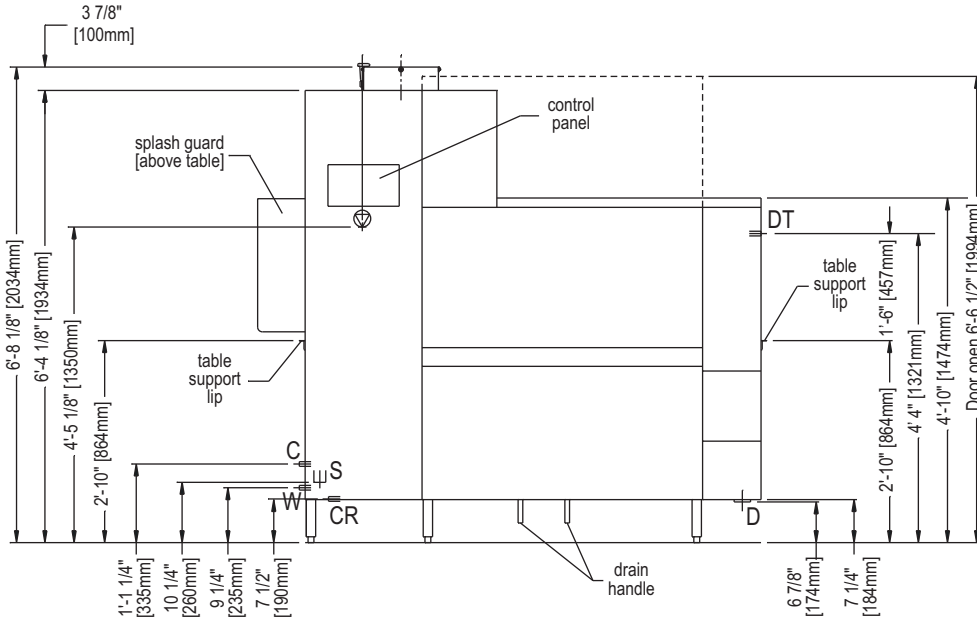

All dimensions from floor +/- 1/2" (13mm) due to adjustable feet.

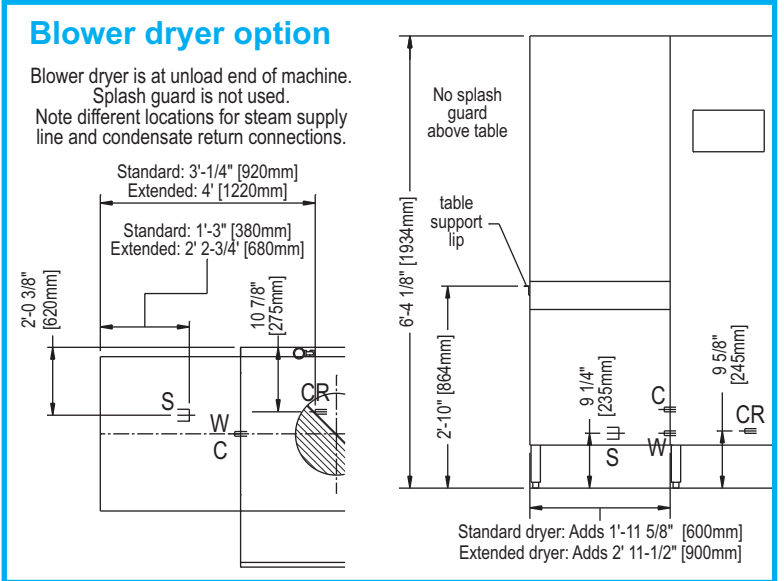
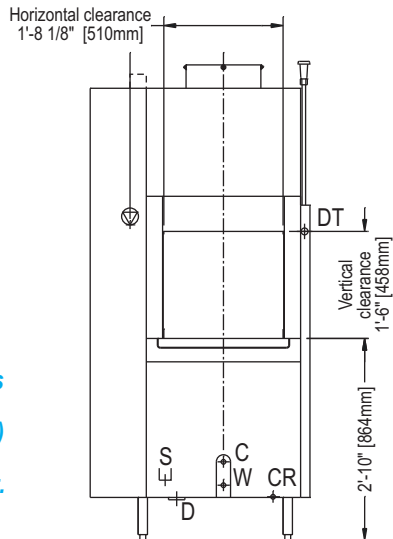

K-200 Series Utility Connections

D Drain

- 2-15/16" (75mm) OD vertical, gravity-fed drain outlet (HDPE piping). Optional 3" NPT male adapter supplied. Recommend placement directly above 4" floor drain. Additional piping to drain (if so required) to be supplied by customer.
- Connection is 6-7/8" (174mm) AFF. If using optional 2" NPT adapter, connection is 5-5/8" (144mm) AFF. Refer to **Detail View: Drain** for suggested connection.

Electrical connection(s)

- Steam-heated machines have a single electrical terminal block.
- Electrically-heated machines have three or four electrical terminal blocks:
 - 1 - Motors and controls
 - 2 - Wash tank heaters
 - 3 - Booster heaters
 - 4 - Blower dryer heaters (if present)
 All connections are 4-wire with ground - no neutral.
- Incoming leads must be appropriately sized for electrical supply. Opening(s) in the machine for the supply lines are NOT provided and should be executed on-site using appropriate strain relief device(s).
- Connection for steam-heated machines, and terminal blocks 1-3 for electrically-heated machines, are 4' 5-1/8" (1350mm) AFF.
- Connection at terminal block 4 for electrically-heated machines is 10-3/8" (264mm) AFF.
- Refer to utility chart on Page 7 for electrical load information.

Vent connection

- Refer to **Detail View: Vent** for suggested connection.
- The waste air connection must be corrosion-resistant and frost-free. In particular, provisions must be made to prevent air temperatures of 32°F (0°C) or colder from reaching the machine at any time. A provision for draining moisture from the waste air pipe is strongly recommended.
- Machine exhaust, without blower dryer: 354 CFM (602m³h)
- Machine exhaust, with blower dryer: 388 CFM (651m³h)
- Additional room air recommended for indirect vent: 120 CFM (170m³h)

DT Detergent

Connection is 4' 4" (1321mm) AFF. For model K-200 without CSS Top, a dummy plug covers hole for external detergent line. For all other models, provided hole is end of pre-plumbed detergent conduit. Feed external detergent line to wash tank.

IMPORTANT: Ensure tabling does not block detergent port!

C Cold water connection (final rinse)

- 3/4" NPT pipe connection is 1' 1-1/4" (335mm) AFF.
- Temperature cold as available (50°F / 10°C optimum)
- Consumption 84.7 gals. (320.6 liters) per hour
- Recommended hardness 1-6 grains/U.S. gal.

W Warm water connection (fill)

- 3/4" NPT pipe connection is 9-1/4" (235mm) AFF.
- Temperature 110-140°F (43-60°C)
- Initial fill:
 - K-200 - 37.0 gals. (140 liters)
 - K-200 PW - 52.8 gals. (200 liters)
 - K-200 LPW - 60.7 gals. (230 liters)
 - CSS Top option (if present) - add 10.6 gals (40 liters)
- Recommended hardness 1-6 grains/U.S. gal.

S Steam connection (steam-heated machines)

- 2" NPT pipe connection
- Machines without blower dryer: pipe connection is 10-1/4" (260mm) AFF.
- Machines with blower dryer: pipe connection is 9-1/4" (235mm) AFF.
- 10-30 PSI CONSTANT steam pressure is REQUIRED. If pressure is above 30 PSI, use of a regulator is REQUIRED (supplied by customer).
- The pipe connection does NOT reflect the steam line size from the boiler to the dishwasher. The necessary steam line sizing must be determined by the facility's steam engineer based on the pressure and volume requirements.
- Consumption 187 lbs. per hour (51kW)

CR Condensate return connection (steam-heated machines)

- 1" NPT pipe connection
- Machines without blower dryer: pipe connection is 7-1/2" (190mm) AFF.
- Machines with blower dryer: pipe connection is 9-5/8" (245mm) AFF.
- Condensate line MUST be pressure-free.

Drain Connection

The machine is equipped with a 2-15/16" (75mm) OD vertical, gravity-fed drain. If possible, the machine drain can simply be positioned directly above a 4" floor drain.

If a floor drain is not in the correct location, or if local codes require a trap, a 2" indirect drain line may be attached using the supplied 2" NPT male adapter.

Choose a piping material that:

- Complies with any applicable local and national codes
- Is rated for use with water temperatures up to 180°F/82°C
- Is rated for 3-12 pH to accommodate detergents and rinse aid in the drain water

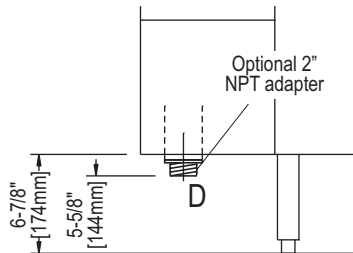

Recommended Tabling Construction

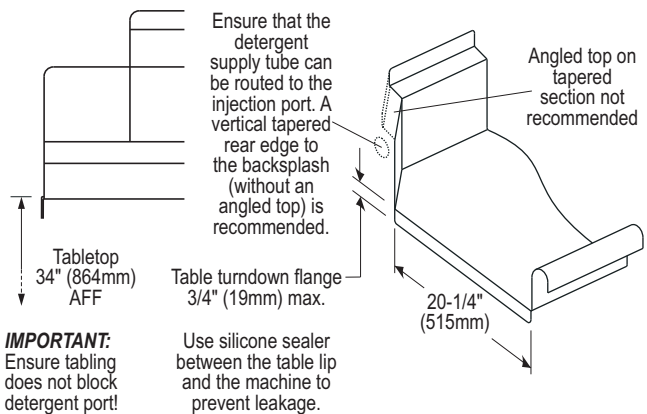

Vent Connection

CFM ratings shown are recommended values only. Exhaust connection must be adequate for the exhaust air and comply with all applicable national and local codes.

Supplied with machine:

- Machine vent
- Vent collar. Attaches to top of machine at 4 positions
- Condensate drain tube

By others:

- Square vent duct. Sleeves inside vent collar. Attaches 3 positions per side (12 total). Attachment hardware to comply with all applicable national and local code requirements.

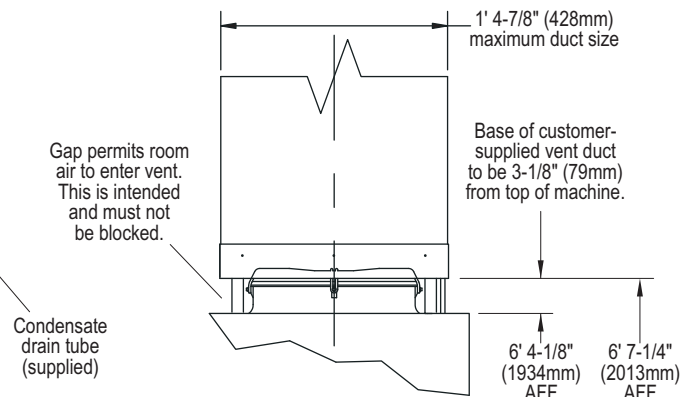
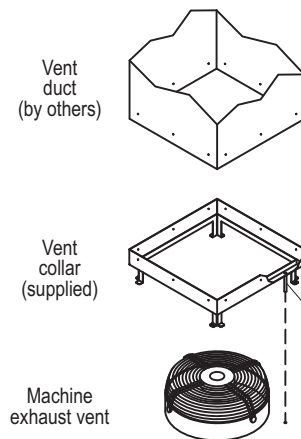

K-200 Series Technical Specifications

Operating Capacities

Racks per hour (NSF rated)	306
Racks per hour (standard)	240
Dishes per hour	6,000
Glasses per hour	8,640

Conveyor Specifications

Conveyor belt speed (NSF rated)	8.51 feet/min. (2.59m/min.)
Conveyor belt speed (standard)	6.67 feet/min. (2.03m/min.)
Horizontal clearance	1' 8-1/8" (510mm)
Vertical clearance	1' 6" (458mm)

Water Specifications

Minimum water temperatures:	
Prewash tank	No minimum - 110-140°F (43-60°C) typical
Wash tank	160°F (72°C)
Auxiliary rinse tank	165°F (74°C)
Final rinse	180°F (82°C)
Incoming water temperatures:	
Final rinse connection	Cold as available (50°F / 10°C optimum)
Tank fill connection	110-140°F (43-60°C)
Initial fill	
K-200	37.0 gals. (140 liters)
K-200 PW	52.8 gals. (200 liters)
K-200 LPW	60.7 gals. (230 liters)
CSS Top option (all)	Add 10.6 gals. (40 liters)

Venting Specifications

Machine exhaust, without blower dryer	354 CFM (602m³/h)
Machine exhaust, with blower dryer	383 CFM (651m³/h)
Additional room air recommended for indirect vent	120 CFM (204m³/h)
Total	
Machines without blower dryer	474 CFM (806m³/h)
Machines with blower dryer	503 CFM (855m³/h)

Incoming water line size

Final rinse connection	3/4" NPT
Fill connection	3/4" NPT
Recommended water hardness	1-6 grains/U.S. gal.
Consumption at 100% capacity:	84.7 gals. (320.6 liters)/hr. 0.35 gals. (1.34 liters)/rack
Final rinse flow rate	1.41 gals.(5.34 liters)/min.
Drain line size	2-15/16" (75mm) OD, 2" NPT adapter supplied
Maximum drain flow rate	15 gals. (56.8 liters) per minute

Machine Electrical Specifications

	208 V/60 Hz/3 Ph				230 V/60 Hz/3 Ph				460 V/60 Hz/3 Ph			
	TB1	TB2	TB3	TB4	TB1	TB2	TB3	TB4	TB1	TB2	TB3	TB4
K-200, electric tank heat	18.3A	66.7A	75.0A	--	18.3A	58.2A	65.5A	--	8.4A	29.8A	33.7A	--
K-200 PW, electric tank heat	20.9A	66.7A	75.0A	--	20.9A	58.2A	65.5A	--	9.8A	29.8A	33.7A	--
K-200 LPW, electric tank heat	28.1A	66.7A	75.0A	--	28.1A	58.2A	65.5A	--	12.3A	29.8A	33.7A	--
K-200, steam coil tank heat	18.3A	--	--	--	18.3A	--	--	--	8.4A	--	--	--
K-200 PW, steam coil tank heat	20.9A	--	--	--	20.9A	--	--	--	9.8A	--	--	--
K-200 LPW, steam coil tank heat	28.1A	--	--	--	28.1A	--	--	--	12.3A	--	--	--
CSS Top	+3.9A	--	--	--	+3.9A	--	--	--	+2.3A	--	--	--
Blower dryer, electrically-heated machines	--	--	--	16.0A	--	--	--	14.0A	--	--	--	9.2A
Blower dryer, steam coil-heated machines	+16.0A	--	--	--	+14.0A	--	--	--	+9.2A	--	--	--

Motor ratings

Wash pump motor	3.0 hp (2.2 kW)
Prewash pump motor, K-200 PW only	0.75 hp (0.55 kW)
Prewash pump motor, K-200 LPW only	3.0 hp (2.2 kW)
Auxiliary rinse pump motor	0.75 hp (0.55 kW)
Final rinse pump motor	0.75 hp (0.55 kW)
Conveyor motor	0.125 hp (0.09 kW)
Vent motor	0.25 hp (0.19 kW)
CSS Top pump motor (if equipped)	1.0 hp (0.75 kW)
Blower dryer motor (if equipped)	0.5 hp (0.37 kW)

Electric tank heater ratings (electrically-heated machines only)

Wash tank	24 kW
Auxiliary rinse tank	12 kW
Booster heater	15 kW
Blower dryer heater	3 kW

Steam Specifications (steam-heated units only)

Steam line connection	2" NPT
Condensate return connection	1" NPT

Steam pressure	10-29 psi (1-2 bars)
Steam consumption	187 lbs./hr. (51 kW)*

* NOTE: Steam-heated machines use electrically-heated blower dryer (3 kW).

Note: All specifications are subject to change without notice based on MEIKO's dedicated product improvement program.

Equipment Specification: K-200 Series Rack Conveyor - Item No. _____

Item will be an NSF and ETL-listed MEIKO:

___ **K-200** single tank, rack conveyor dishwasher, consisting of a wash zone with 3 hp pump motor, a pumped auxiliary rinse zone with 3/4 hp pump motor, and a pumped final rinse zone with 3/4 hp pump motor. Total length of the machine (table-to-table) will be 6' 4-3/4" (1950mm).

___ **K-200 PW** single tank, rack conveyor dishwasher, consisting of a prewash compartment with a 3/4 hp pump motor, a wash compartment with a 3 hp pump motor, an auxiliary rinse compartment with a 3/4 hp pump motor, and a final rinse compartment with a 3/4 hp pump motor. Total length of the machine (table-to-table) will be 8' 1/2" (2450mm).

___ **K-200 LPW** single tank, rack conveyor dishwasher, consisting of a prewash compartment with a 3 hp pump motor, a wash compartment with a 3 hp pump motor, an auxiliary rinse compartment with a 3/4 hp pump motor, and a final rinse compartment with a 3/4 hp pump motor. Total length of the machine (table-to-table) will be 9' 1/4" (2750mm).

Unit will utilize an internal booster heater to maintain a 180°F (82°C) minimum fresh water sanitizing rinse. Final rinse will be pumped for constant pressure and consistent rinsing results regardless of variation in water supply pressure. Unit will be NSF-rated with speed of 8.51 feet (2.59m) per minute. Unit will have a capacity of 240 racks per hour at a standard speed of 6.67 feet (2.03m) per minute. Unit will consume an NSF-rated 84.7 U.S. gals. (320.6 liters) per hour (0.35 U.S. gals./1.34 liters per rack).

Electrical characteristics:

___ 208V/60 Hz/3 Ph

___ 230V/60 Hz/3 Ph

___ 460V/60 Hz/3 Ph

Wash tank temperature will be maintained at a minimum of 160°F (72°C). Tank heating will be accomplished by:

___ Thermostatically-controlled electric heating elements

___ Thermostatically-controlled stainless steel steam coils

Direction of conveyor travel will be:

___ Right-to-Left

___ Left-to-Right

Unit will have the following standard features:

- Capacity of 240 racks/hr. and 0.35 gals./rack
- Pumped final rinse for constant pressure and consistent rinsing results regardless of variations in water supply pressure
- Pumped auxiliary rinse zone to supplement the final rinse zone
- Waste air heat recovery system to reclaim heat generated by the machine, using it as free energy to preheat the incoming rinse water
- Double-wall, insulated construction
- Mike 3 electronic controller for fully automatic operation, variable conveyor speeds and advanced service diagnostics
- Wash arm spray pattern that ensures effective coverage with varying angles and offset spray jets. Slotted, concave wash nozzles and captivated end caps to promote easier cleaning
- Rack rail-mounted pawl bar drive system for smooth travel at high speeds and an unobstructed wash pattern
- Front sloping V-shaped wash tank for complete tank drainage, accessibility, and cleanability
- Low level heater protection
- Powerful 3 Hp wash pump motor is self-draining. Pump motor is internal and vertically installed for easy access and serviceability
- Pump housing and impeller constructed of stainless steel
- Single point drain connection
- Single point ventilation connection
- Large front access door(s) can be opened with one hand and remain open without latches, aiding machine accessibility and cleanability
- Large, removable pan strainer(s)
- Models equipped with a prewash include a separate prewash scrap basket
- External vent fan control

Unit will incorporate a MIKE 3 electronic control system that allows operation at 3 different conveyor speeds (maximum 6.57 feet/2.00m per minute, 240 racks per hour) while consuming an NSF-rated 84.7 gals. (320.6 liters) of water per hour (0.35 gals./1.34 liters per rack).

Unit will have the following optional features (check all that apply):

___ Blower dryer system incorporating a single blower and 3kW electric heaters for complete drying of all dishes, crockery and silverware

___ 1' 11-5/8" (600mm) in length

___ 2' 11-3/8" (900mm) in length

___ CSS Top chemical savings system

___ Hinged front access doors

___ Single-point electrical connection (electric heat only)

___ Table limit switch

___ Inline (whisker switch) style

___ End stop style

___ Flanged, bolt-down feet

___ Drain water tempering kit

___ 90° loader

___ 90° power unloader