

ADC-66 Conveyor by

HIGH or LOW temp the ultimate choice...

- **Reliable pre-wash**
- **Unrivalled cleaning ability**
- **Best performance of all listed 66" conveyors**
- **Rated for dual sanitizing**
- **66% less water than industry average**
- **244 racks per hour - .49 gallons water per rack**
- **Auto fill and shut-off standard**

Water Curtain Rinseability

- activates prior to final rinse
- initiates the rinsing process and acts as a shield

- flips open, snaps shut
- quick fast clearing of spray arms
- shortens the cleaning process & eliminates down time

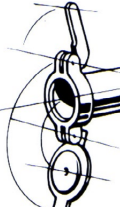

Captive end caps

Dual - Fail Safe Heater Control

- precise water control mechanism
- only allows heaters to operate when tank is full
- unaffected by heavy soil, water action, strong chemicals, and lime build up

Fail - Safe Conveyor System

- slip clutch design - stops rack movement
- once removed operation easily resumes
- eliminates damaged racks

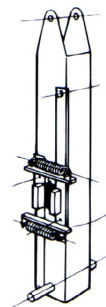

Drain Pump Filter

- 2 stage PUMP STRAINER
- eliminates wash pump obstructions and clogged jets
- functions as drains stopper



Pre-Wash Scrap Basket

- V construction
- keeps soil in tray
- protects pump

At American Dish Service, Quality People, Designs, and Products have been the foundations of our organization for over **45 years**.

www.americandish.com

American Dish Service
 Manufacturers of Ware Washing Equipment

900 Blake Street Edwardsville, KS 66111-3820 **Toll Free (800) 922-2178** **Phone (913) 422-3700** **Fax (913) 422-6630**

ADC-66 Conveyor



- Deep "V" Scrap Tank
- Auto Fill / Auto Start / Shut-off
- Safety Shut-off Scrap Pump
- Overflow Scraping Feature
- Captive Endcaps
- Patented Water Control
- Water Curtain for Final Rinse
- 3 HP Wash Pump,
1.5 HP Scrap Pump
- 244-Racks per Hour,
- 49 Gallons per Rack

Effective 7/02

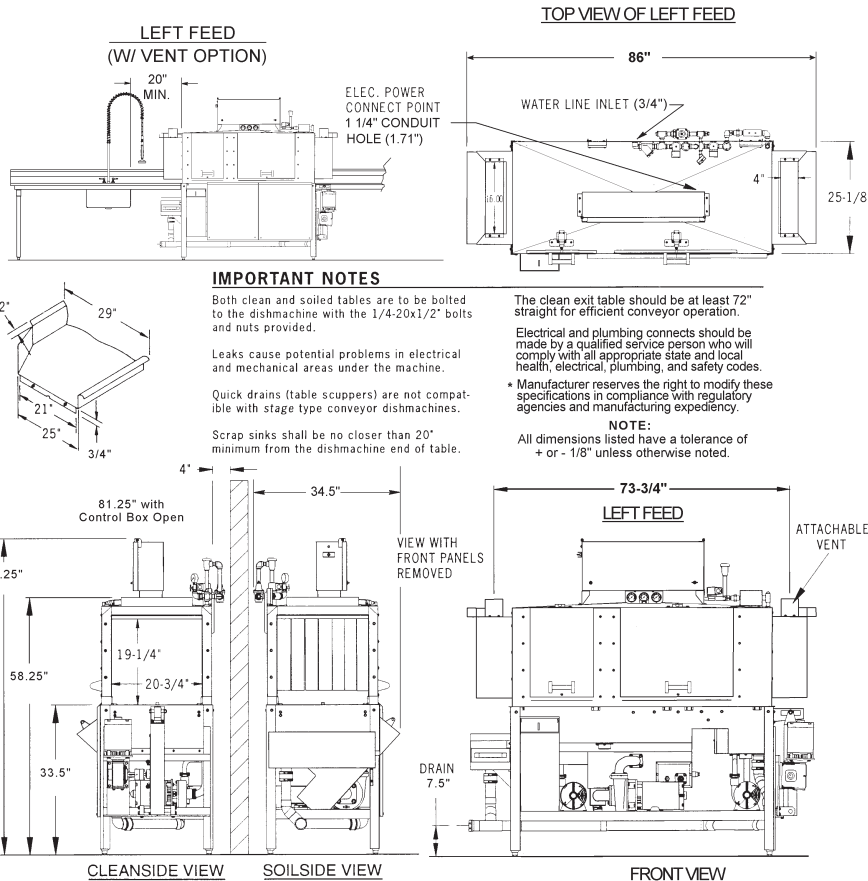

U.S. REGISTERED PATENTS
Model ADC-66 Specifications

ADC-66	FAMILY MODELS (left or right feed)	
	ADC-66 HOT TEMP	ADC-66 CHEMICAL
NSF RATED CAPACITY	244 rack/hr	244 rack/hr
CONVEYOR SPEED	6.8 ft/min or 2.07 meters	6.8 ft/min or 2.07 meters
WATER CONSUMPTION	.49 gal/rack or 1.8 liter	.49 gal/rack or 1.8 liter
TOTAL GAL. PER HR.	120 gph or 454.2 liters	120 gph or 454.2 liters
FINAL RINSE TEMP (20 psi)	180° F/ 82.2 C	120° F/ 48.8 C
SANITIZER	180° WATER	50ppm CHLORINE
ELECTRICAL POWER SUPPLY	. . . 208/240v, 3 ph, 90 a, 60 Hz <small>3 Phase installation requires 3 gauge wires with a 10 gauge neutral wire, a suitable ground, and a clean circuit.</small>	
MOTOR RATINGS 1.5 HP SCRAP, 3 HP WASH 1/3 HP RINSE, 1/3 HP CONVEYOR	
HEATER RATINGS 18KW WASH, 2.25KW RINSE	
RACK SIZE STANDARD 19.75" x 19.75" 50.2 x 50.2 cm	
ACCESS DOOR CLEARANCE 15" x 24.5" 38.1 x 62.2 cm	
RACK CLEARANCE (Through machine) 19.25" x 20.75" 48.9 x 52.7 cm	
WATER INLET (3/4") F.P.T.	
DRAIN SIZE (2") F.P.T.	
HEIGHT (with door open) 73.75" (84.25" or 213.9 cm with control box cover open)	
WIDTH (Overall) 86" 218.4 cm	
WIDTH, TABLE TO TABLE 66" 167.6 cm	
DEPTH 34.5" 87.6 cm	
SHIPPING WEIGHT 978 POUNDS 444 kg	
SHIPPING DIMENSIONS 86" L x 44" W x 80" H 218.4 cm x 111.76 cm x 203.2 cm	

Effective: 10/02

© 10/02

WARNING: Cancer and Reproductive Harm - www.P65Warnings.ca.gov

ADS has built a strong history based on Customer Service, Quality and Reliability. A Commitment to Excellence is the driving force behind American Dish Service.

900 Blake Street Edwardsville, KS 66111-3820 **Toll Free (800) 922-2178** **Phone (913) 422-3700** **Fax (913) 422-6630**