



### Features

**150 lb (68 kg) undercounter ice storage**

**Upscale drink station**

- low profile with ice storage under the counter
- auto-fill with an ice machine out of view using RIDE® remote ice delivery equipment
- ideal for island configurations
- fits into ADA compliant 34.00" (86.4 cm) counters

**Optimized throughput with customizable left or right side ice dispense chute – customers fill cups faster for shorter lines**

**Integral ice-water-bath beverage cooling option located behind beverage valves – delivers cold, high quality beverages and excellent casual drink performance**

**Durable, full stainless exterior**

**Easier beverage connections**

- beverage valves with factory installed beverage lines for easy field connection
- four center valves configured as QuickCARB™ valves, individually changeable from carbonated to non-carbonated flavors without disconnecting water lines

**Pre-configured for Follett® RIDE model Chewblet® ice machines**

- connect up to two Follett ice machines
- user-preferred, chewable compressed nugget ice
- slow melting, maintains drink temperature
- accepts Chewblet ice or Micro Chewblet™ ice

**Faster, safer manual loading of ice at waist height**

- safe, easy waist-height loading front or rear
- eliminates overhead lifting of buckets or loading from ladders
- allows quick reloading during serving period with minimal disruption
- may be manually loaded with cube ice up to 1.00" (2.54 cm) square



VU155 series				
Integral beverage cooling	# of valves	Ice tower location	Valve type	Item number
with	8	left	lever	<b>VU155B8LL</b>
			push-button	<b>VU155B8LP</b>
		right	lever	<b>VU155B8RL</b>
			push-button	<b>VU155B8RP</b>
	10	left	lever	<b>VU155B10LL</b>
			push-button	<b>VU155B10LP</b>
right		lever	<b>VU155B10RL</b>	
		push-button	<b>VU155B10RP</b>	

Standard with Cornelius UFB1 valves.  
Lancer LEV valves available for Coke users only (add -LAN to end of model number).

### Accessories

6.00" (15.24 cm) stainless steel leg kit (set of 4) adjustable to 9.00" (22.86 cm) (item# AFLEGKT155)

Integration kit – Required to integrate with Ice Manager™ diverter valve (item# VUIMDVKIT)

Job

Item

## Specification

Ice storage capacity	150 lb (68 kg)
<b>W</b> Width	8 valve models – 31.25" (79.4 cm) 10 valve models – 37.25" (94.6 cm)
<b>D1</b> Depth	27.38" (69.6 cm)
<b>D2</b> Depth, drain pan interior	7.38" (18.75 cm)
<b>H1</b> Height, upper section	22.00" (55.9 cm)
<b>H2</b> Height, lower section	27.88" (70.8 cm)
<b>H3</b> Height, leg	adjustable 6.00" - 9.00" (15.24 - 22.86 cm)
<b>H4</b> Ice dispense height clearance	10.00" (25.4 cm)
<b>K1</b> Ice dispense chute	utility connections are on opposite side of ice dispense chute
<b>L1</b> Countertop to lever	7.88" (20.02 cm)
<b>L2</b> Front of dispenser to lever	6.88" (17.48 cm)
Installation clearance	51.00" (129.5 cm) above counter for drop-in installation, 1.25" (3.18 cm) maximum counter thickness
Service clearance	12.00" (30.5 cm) minimum on side opposite of ice chute (and on side transport tube enters), 36.00" (91.4 cm) minimum above counter for auger removal
NOTE: For additional information refer to form# 3105.	
<b>C1</b> Electrical	4.4 amps. 8' (2.4 m) cord and NEMA 5-15 90° plug provided with each dispenser. Separate circuits and disconnects required for each dispenser.
115 V/60/1	
<b>C2</b> Drain - ice storage	3/4" PVC slip joint
<b>C3</b> Drain - beverage water bath	1.00" ID hose
<b>C4</b> Drain - drain pan	3/4" PVC hose
<b>C5</b> Beverage lines	1/4" ID syrup beverage hose, 3/8" ID carbonated water beverage hose, 3/8" ID plain water beverage hose
<b>C6</b> Ice machine electrical connection	Pre-wired bin signal junction box with twist lock connector(s). Standard length is 20' (6.1 m).
<b>C7</b> Ice machine ice transport tube connection	two ice transport tube entry holes on each side
Approximate net weight	270 lb (123 kg)
Approximate shipping weight	301 lb (137 kg)
NOTE: For indoor use only	

**SHORT FORM SPECIFICATION:** Ice and beverage dispenser to be Follett model \_\_\_\_\_. Dispenser to store up to 150 lb (68 kg) of ice and allow loading of ice at waist level from front or rear. Full-length drain to be one-piece molded polyethylene. Beverage rail to have (choose one) \_\_\_ eight (8) or \_\_\_ ten (10) Cornelius UFB1 valves. Beverage rail to be of stainless steel with plastic trim. Beverage manifold to be pre-plumbed with center 4 valves individually changeable from carbonated to non-carbonated flavors without disconnecting water lines. To include 6.00" - 9.00" (15.24 - 22.86 cm) adjustable legs for dispenser support. Storage area to be insulated with CARB compliant non-HFC foam. Electric keyswitch standard. Dispenser to be pre-configured to accept up to two \_\_\_\_\_ RIDE model ice machines, sold separately. 8' (2.4 m) cord and NEMA 5-15 90° hospital grade plug provided. NSF, UL and cUL listed.

## VU155 series

2780-201912 | © Follett LLC



## Dimensional drawing

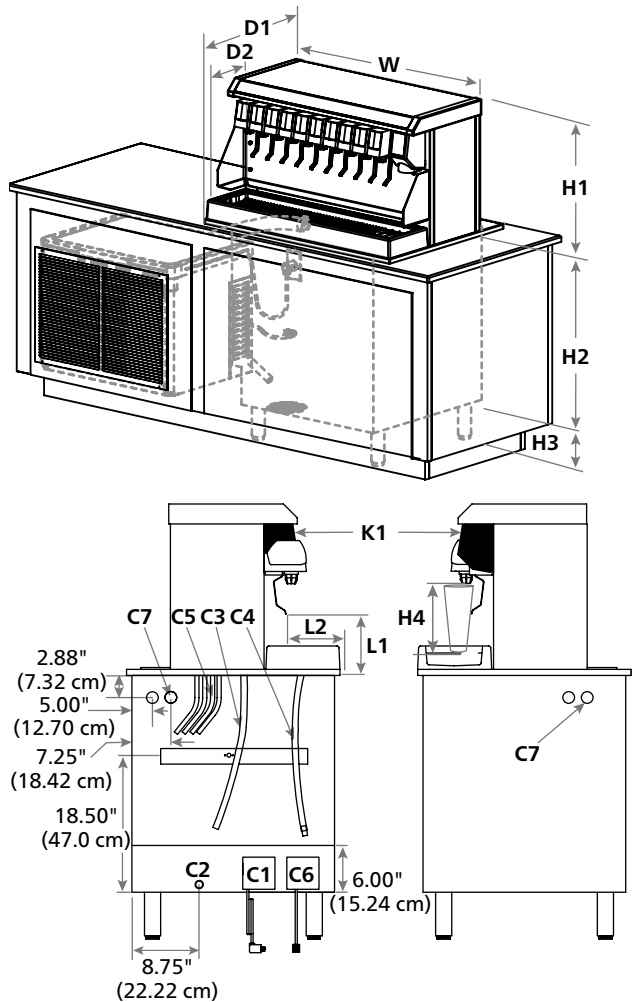

## Counter cutout detail

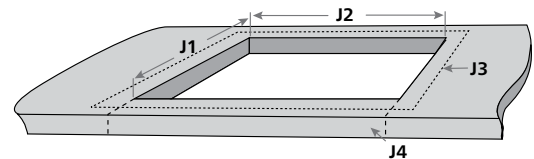

### VU155 – 8 valve unit

- J1** Cutout depth 26.25" (66.68 cm) ± .0125" (.0317 cm)
- J2** Cutout width 30.375" (77.152 cm) ± .0125" (.0317 cm)
- J3** Flat surface 31.25" (79.38 cm) W x 28.00" (71.12 cm) D required
- J4** Optional – counter front may be removed for slide-in installation

### VU155 – 10 valve unit

- J1** Cutout depth 26.25" (66.68 cm) ± .0125" (.0317 cm)
- J2** Cutout width 36.375" (92.392 cm) ± .0125" (.0317 cm)
- J3** Flat surface 37.25" (94.62 cm) W x 28.00" (71.12 cm) D required
- J4** Optional – counter front may be removed for slide-in installation

ICE MANAGER, MICRO CHEWBLET, QUICKCARB and VISION are trademarks of Follett LLC. CHEWBLET, FOLLETT and RIDE are registered trademarks of Follett LLC, registered in the US. Follett reserves the right to change specifications at any time without obligation. Certifications may vary depending on country of origin.

801 Church Lane | Easton, PA 18040, USA  
1.800.523.9361 | 1.610.252.7301 | follettice.com

**FOLLETT**