



BLCT-101E

BLCT-101E

Single Boilerless
Electric Combination-Oven/Steamer
with Touchscreen Control



Shown on optional stand with casters

Project _____

Item No. _____

Quantity _____

- Standard rack with 3.35" (85mm) spacing holds eight 12" x 20" x 2-1/2" deep North American hotel pans
- Optional rack with 2.56" (65mm) spacing holds ten 12" x 20" x 2" deep Gastronorm pans

Refer to operator manual specification chart for listed model names.

CONSTRUCTION

- 304 stainless steel exterior and interior
- Dual pane tempered viewing window with hinged inner glass for easy cleaning
- 2" (50mm) fixed drain in the bottom center of cavity
- Door mounted drip tray reduces the risk of wet, slippery floors
- Automatic door stops in positions of 110° and 180°
- Left hinge door is field convertible to the right side (with the purchase of conversion kit)
- Two step safety door latch. The first step stops the fan.

OPERATION

- Injection steam system - water is injected onto the heating elements, the resulting steam is distributed in the oven chamber by the fan wheel.
- Easy to use touchscreen control
- Multiple cooking modes include hot air, CombiSmart, CombiOptima, retherm, steaming, low-temperature steaming, forced steaming, proofing, preheating
- Stores up to 500 recipes with up to 15 steps each
- Manual or automatic cooling
- Automatic humidity pulsing
- External core temperature probe
- Rack timing allows for setting individual timers for each rack
- Reversible 9 speed fan for optimum baking and roasting results
- USB port for data and recipe transfer
- HACCP recording and documentation
- Automated CombiWash, closed circuit cleaning system features very low water and detergent consumption and no contact with chemicals. No proprietary chemicals required, see owner's manual for detergent guidelines.

STANDARD FEATURES

- External core temperature probe with multiple measuring points
- 21-1/2" tall stainless steel stand with runners & adjustable feet
- Bright halogen lights for superior visibility
- Built in hand shower
- Removeable cleaning chemical bottle shelf
- 8 wire shelves
- Start-up inspection service by factory authorized service agent
- One year parts and labor oven warranty*

* For all international markets, contact your local distributor.



OPTIONS AND ACCESSORIES

(AT ADDITIONAL CHARGE)

■ Legs and Stands

- 21-1/2" tall stainless steel stand with runners & casters
- Adjustable feet for table top installation

■ Banquetting Accessories

- Pan cassette with 2.56" (65mm) spacing
- Pan cassette with 3.35" (85mm) spacing
- Plate cassette with 2.56" (65mm) spacing holds 20 plates
- Plate cassette with 3.35" (85mm) spacing holds 15 plates
- Cassette support platform
- Transport trolley, to move the cassette
- Insulated thermal blanket with vent
- Wire oven rack
- Right hinge door
- Backflow preventer
- Extra year warranty

OPTIONS AND ACCESSORIES

(AT NO CHARGE)

- Optional rack w/ 2.56" (65mm) spacing & 10 wire shelves in lieu of standard rack & shelves

BLODGETT OVEN COMPANY

www.blodgett.com • 42 Allen Martin Drive, Essex Junction, VT 05452 • Phone: (802) 658-6600 • Fax: (802) 864-0183



BLCT-101E

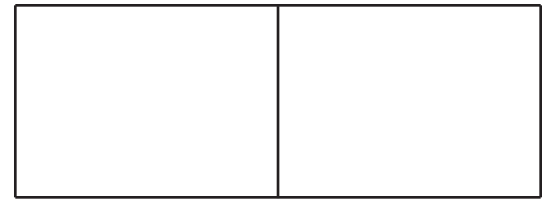

APPROVAL/STAMP

DIMENSIONS ARE IN INCHES (MM)

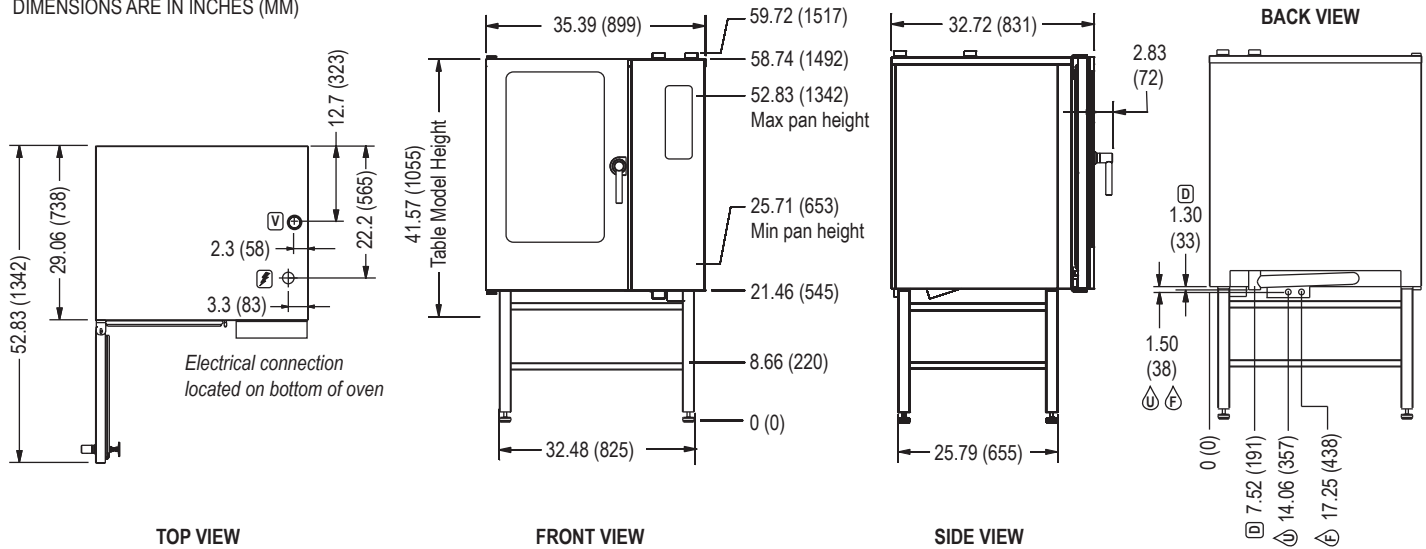

SHORT FORM SPECIFICATIONS: Provide Blodgett Combi model BLCT-101E boilerless combination-oven/steamer. The BLCT-101E has a 2 piece rack system with 3.35" (85mm) rack spacing that holds eight 12" x 20" x 2-1/2" deep North American hotel pans. The optional 2 piece rack system with 2.5" (65mm) spacing holds ten 12" x 20" x 2" deep Gastronorm pans. Unit shall have 304 stainless steel exterior and interior. Oven door shall have dual pane tempered viewing window with hinged inner glass for easy cleaning. Unit shall have the ability to cook with pressureless steam, hot air, or combination of steam and hot air. Unit shall have steam injection system. Multiple modes include hot air, combi with CombiOptima, retherming, steaming, low-temperature steaming, forced steaming, proofing, cooling, and preheating. Unit shall have bright halogen lights for superior visibility. Touchscreen control stores 500 recipes with 15 stages each, in addition to pre-programmed recipes. External core temperature probe, rack timing allows for setting individual timers for each rack, HACCP quality control, USB connectivity, automatic service diagnosis. The reversible 9 speed fan provides optimum baking and roasting results. Automated CombiWash, closed circuit cleaning system features very low water and detergent consumption and no contact with chemicals. One-year parts and labor warranty. Provide start-up inspection service by a factory authorized service agent. Provide options and accessories as indicated.

DIMENSIONS:

Floor space: 35.39" x 32.72" (899 x 831mm)
Unit height:
 Oven on stand 58.74" (1492mm)
 Table model 41.57" (1055mm)

OVEN CLEARANCES:

From combustible and non-combustible construction

Right 4" (102mm)
 Left 0" (0mm)
 Back 2" (50mm)

Blodgett recommends and 12" (305mm) be maintained on the control side for servicing.

MINIMUM ENTRY CLEARANCE:

Uncrated 29.06" (738mm)
 Crated 38" (965mm)

POWER SUPPLY:

Voltage	KW	Phase	Amperage
208 VAC	18	3	50
240 VAC	18	3	44
480 VAC	18	3	22

Other voltages available, contact factory

WATER SUPPLY & DRAIN:

Good quality water feed is the responsibility of the owner. Water quality must be within the following general guidelines.

TDS: 40-125 ppm Hardness: 35-100 ppm pH: 7.0 - 8.5
 Silica: <13 ppm Chlorides: <25 ppm Chlorine: <0.2 ppm
 Chloramine: <0.2 ppm

The best defense against poor water quality is a water treatment system designed to meet your water quality conditions. Blodgett offers optional systems from Optipure.

Pressure: 40(min)-50(max) PSI
 Connections: 2" drain connection - max. drain temperature 140°F (60°C)
 3/4" garden hose cold water

The drain piping must consist of temperature resistant material, greater than 160°F, and be of adequate diameter not to cause flow restriction. Improper materials may deform and cause restrictions, thus affecting performance.

Appliance is to be installed with backflow protection in accordance with federal, state or local codes.

SHIPPING INFORMATION:

Approx. weight: 535 lbs. (242 kg)

Crate size:

Oven 40" H x 47" W x 38" D (1016 x 1194 x 965 mm)
 Stand 36" H x 42" W x 35" D (914 x 1067 x 889 mm)

NOTE: The company reserves the right to make substitutions of components without prior notice

BLODGETT OVEN COMPANY

www.blodgett.com • 42 Allen Martin Drive, Essex Junction, VT 05452 • Phone: (802) 658-6600 • Fax: (802) 864-0183